



Product sheet

ComDry M170L
Desiccant dehumidifier

- Product upgrade with new silent fan
- Noise reduced from 65dB(A) to 58dB(A)



- Compact
- Lightweight
- Humidity temp sensor
- Air cooled condenser
- Condensate pump
- Reliable
- Energy efficient
- kW counter
- Remote control option



ComDry M170L

The ComDry series is a range of desiccant dehumidifiers with high drying capacity, reliability and low energy consumption. The solid casing is excellent at withstanding corrosion and the dehumidifiers robustness makes it very versatile in a wide range of applications. They are also easy to stack and transport.

Munters ComDry series is particularly suited to water and fire damage restoration operations as well as archives, waterworks and the construction industry. ComDry units can also be used to reduce the relative humidity in storage rooms, cellars, archives and other limited spaces.

The ComDry M170L is designed for applications in closed rooms, unheated basements or where it is prohibited to keep windows open overnight due to security/insurance issues. An air cooled condenser recycles the reactivation air whilst ambient air is cooled below its dewpoint. The resulting water droplets extracted from the air are collected in a drip tray and pumped away with a built in drainage pump. Easy to maintain Munters ComDry M170L is the perfect choice for mobile and static preservation applications. All Munters dehumidifiers are based on the rotor technology specially developed by Munters which provides high moisture-absorbing capacity. The flexible design and good performance of the rotor mean that there are almost no limits to its areas of use.



ComDry M170L

Dimensions

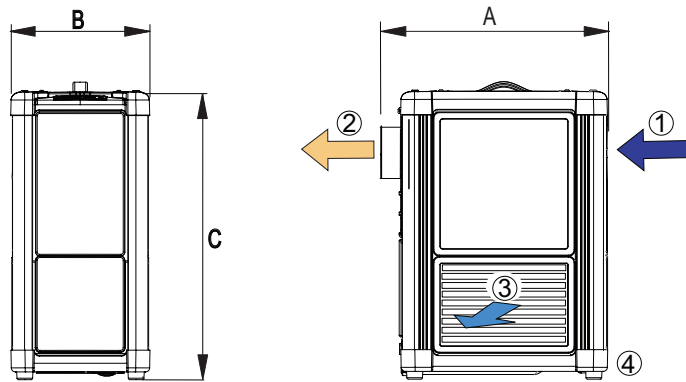

1. Process air in 2. Dry air out 3. Cooling air 4. Drain outlet

Width A	Depth B	Height C	Dry air out	Weight	Drain hose
445mm	270mm	555mm	100mm	17kg	d=6mm

Diagram measurements are for reference only.
Scaled and dimensioned drawings are available from Munters.

Technical specifications

Dry Air		
Maximum airflow	170	m ³ /h
Rated airflow at 60Pa	150	m ³ /h
Maximum static pressure	225	Pa
Condensation Pump		
Max. pump distance horizontal	12	m
Max. pump distance vertical	3	m
Total Power, Voltage & Current		
Total power	1.02	kW
Heater power	0.84	kW
230V 1-50/60Hz	4.4	A
115V 1-50/60Hz	8.8	A
Miscellaneous Data		
Operating temperature	0/+30	°C
IEC protective class	33	unit IP
IEC Protective class, control board	54	IP
Filter class	G3	-
Max noise level	58	dB(A)

- Robust aluminium / plastic casing
- Air cooled condenser
- Condensate pump
- Humidity control
- Multifunction control displaying RH (%), X (g/KG) or Dp (oC)
- Resettable kW and hour counter
- Socket for external sensor
- Filter change without tools
- 2.75m rubber cable
- Modulating heater
- 3.2m drain hose

Options

- External sensor
- External signal box
 - Remote on/off
 - Operation
 - Alarm
- Remote control via external control panel
- Ducted air inlet
- Wall bracket

Dehumidification Capacity

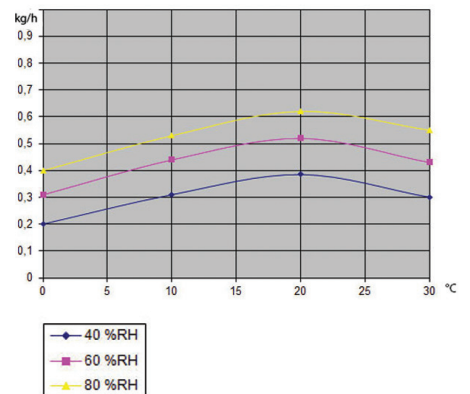

This may not, depending on conditions, correspond to actual drained water volume.

For more information visit
munters.com



Australia Phone +61 2 8843 1588, dh.info@munters.com.au **Austria** Phone +43 1 6164298-92-51, lufentfeuchtung@munters.at **Belgium** Phone +32 1528 5611, info@muntersbelgium.be **Brazil** Phone +55 41 3317 5050, munters@com.br **Canada** Phone +1 905 564 6466, dhinfo@munters.com **China** Phone +86 10 8048 3493, info@munters.com.cn **Czech Republic** Phone +420 775 569 657, info@munters-odvlhcovani.cz **Denmark** Phone +45 4495 3355, info@munters.dk **Finland** Phone +358 20 776 8230, laitemyynti@munters.fi **France** Phone +33 1 3411 5757, dh@munters.fr **Germany** Phone +49 4087 96900, mgd@munters.de **India** Phone +91 20 668 18 900, info@munters.in **Italy** Phone +39 0183 52 11, marketing@munters.it **Japan** Phone +81 3 5970 0021, mkk@munters.co.jp **Korea** +82 2761 8701, munters@munters.co.kr **Mexico** Phone +52 81 8262 5400, munters@munters.com.mx **Netherlands** Phone +31 172 433231, vochtbeheersing@munters.nl **Poland** Phone +48 58305 3517, dh@munters.pl **Singapore** Phone +65 6744 6828, info@munters.com.sg **South Africa** Phone +27 11 971 9700, info@munters.co.za **Spain** Phone +34 91 640 09 02, marketing@munters.es **Sweden** Phone +46 8 626 63 00, avfukning@munters.se **Switzerland** Phone +41 52 343 8886, info.dh@munters.ch **Thailand** Phone +66 2642 2670, info@munters.co.th **Turkey** Phone +90 262 751 3750, info@muntersform.com **UAE** +971 4 8809295, middle.east@munters.com **United Kingdom** Phone +44 1480 432 243, dryair@munters.co.uk **USA** Phone +1 978 241 1100, dhinfo@munters.com **Vietnam** Phone +84 8 8256 838, vietnam@muntersasia.com

