



Product sheet

ComDry M210X
Desiccant dehumidifier

- Product upgrade with new silent fan
- Noise reduced from 65dB(A) to 58dB(A)



- Compact
- Lightweight
- Humidity / temp sensor
- Fast drying
- Robust
- Reliable
- Energy efficient
- kW counter
- Remote control option



ComDry M210X

The ComDry series is a range of desiccant dehumidifiers with high drying capacity, reliability and low energy consumption. The solid casing is excellent at withstanding corrosion and the dehumidifiers robustness makes it very versatile in a wide range of applications. They are also easy to stack and transport.

Munters ComDry series is particularly suited to water and fire damage restoration operations as well as archives, waterworks and the construction industry. ComDry units can also be used to reduce the relative humidity in storage rooms, cellars, archives and other limited spaces.

The ComDry M210X's low weight makes it very effective for frequent mobile applications and it is equally easy to maintain. Filter replacement is quick and simple without the need for any tools. Furthermore the high static pressure within the dehumidifier makes booster fans unnecessary when dehumidifying wooden floors or inflating foil cushions. Munters ComDry M210X is the ultimate dehumidification choice for restoration and preservation applications.

All Munters dehumidifiers are based on the rotor technology specially developed by Munters which provides high moisture-absorbing capacity. The flexible design and good performance of the rotor mean that there are almost no limits to its areas of use.



ComDry M210X

Dimensions

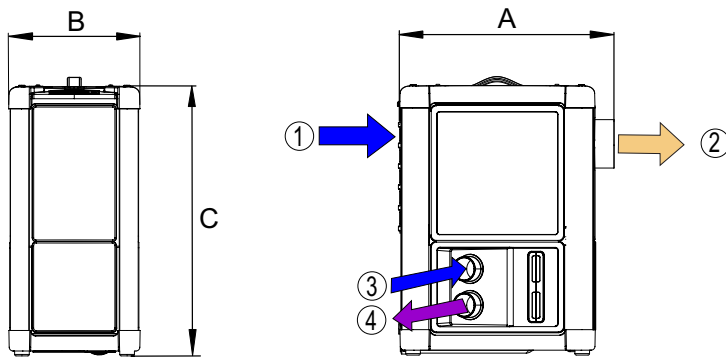

1. Process air inlet 2. Dry air outlet 3. Reactivation air inlet 4. Wet air out

Width A	Depth B	Height C	Dry air out	React air in	Wet air out	Weight
445mm	270mm	555mm	100mm	50mm	50mm	15.0kg

Diagram measurements are for reference only.
Scaled and dimensioned drawings are available from Munters.

- Robust aluminium / plastic casing
- Lightweight
- Built in humidity / temp sensor
- Humidity control
- Multifunction control displaying RH (%), X (g/KG) or Dp (oC)
- Resetable kW and hour counter
- Socket for external sensors
- Filter change without tools
- 2.75m rubber cable
- Modulating heater

Options

- External sensor
- External signal box
 - Remote on/off
 - Operation
 - Alarm
- Remote control via external control panel
- Ducted air inlet
- Wall bracket

Technical specifications

Process air		
Maximum airflow	240	m ³ /h
Rated airflow at 60Pa	210	m ³ /h
Maximum static pressure	250	Pa
Reactivation air		
Rated airflow	25	m ³ /h
Static pressure at rated airflow	70	Pa
Total Power, Voltage & Current		
Total power	1.01	kW
Heater power	0.84	kW
230V 1-50/60Hz	4.4	A
115V 1-50/60Hz	8.8	A
Energy consumption 20°C, 60%	1.51	(kWh/kg)
Miscellaneous Data		
Operating temperature	-20/+40	°C
IEC protective class	33	unità IP
IEC Protective class, control board	54	IP
Filter class	G3	-
Max noise level	58	dB(A)

Dehumidification Capacity

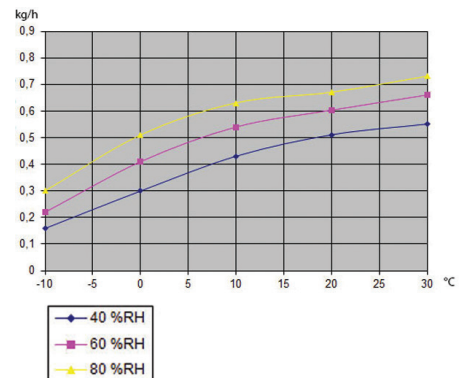

For more information visit
munters.com



Australia Phone +61 2 8843 1588, dh.info@munters.com.au **Austria** Phone +43 1 6164298-92-51, lufentfeuchtung@munters.at **Belgium** Phone +32 1528 5611, info@muntersbelgium.be **Brazil** Phone +55 41 3317 5050, munters@com.br **Canada** Phone +1 905 564 6466, dhinfo@munters.com **China** Phone +86 10 8048 3493, info@munters.com.cn **Czech Republic** Phone +420 775 569 657, info@munters-odvlhcovani.cz **Denmark** Phone +45 4495 3355, info@munters.dk **Finland** Phone +358 20 776 8230, laitemyyni@munters.fi **France** Phone +33 1 3411 5757, dh@munters.fr **Germany** Phone +49 4087 96900, mgd@munters.de **India** Phone +91 20 668 18 900, info@munters.in **Italy** Phone +39 0183 52 11, marketing@munters.it **Japan** Phone +81 3 5970 0021, mkk@munters.co.jp **Korea** +82 2761 8701, munters@munters.co.kr **Mexico** Phone +52 81 8262 5400, munters@munters.com.mx **Netherlands** Phone +31 172 433231, vochtbeheersing@munters.nl **Poland** Phone +48 58305 3517, dh@munters.pl **Singapore** Phone +65 6744 6828, info@munters.com.sg **South Africa** Phone +27 11 971 9700, info@munters.co.za **Spain** Phone +34 91 640 09 02, marketing@munters.es **Sweden** Phone +46 8 626 63 00, avfukning@munters.se **Switzerland** Phone +41 52 343 8886, info.dh@munters.ch **Thailand** Phone +66 2642 2670, info@munters.co.th **Turkey** Phone +90 262 751 3750, info@muntersform.com **UAE** +971 4 8809295, middle.east@munters.com **United Kingdom** Phone +44 1480 432 243, dryair@munters.co.uk **USA** Phone +1 978 241 1100, dhinfo@munters.com **Vietnam** Phone +84 8 8256 838, vietnam@muntersasia.com

