

MK Series

Mobile Cooling dehumidifiers



Cooling dehumidifiers with digital display

Modern technology can only be accomplished with the help of digital components. Consequently Munters MK-series, utilizing a built-in RH/T sensor in combination with the digital multifunctional display, guarantees intelligent as well as cost effective dehumidification.

Their most suitable area of use is within the water and fire damage restoration business as well as the construction industry. Of course they also protect pipes and fittings from corrosion and condensate in waterworks. They can also be used reducing relative humidity in storage rooms, cellars, archives and other limited storage spaces. The dehumidifiers are equipped with adjustable handles to increase flexibility. For higher mobility as well as protection of inventory bumpers and wheels are covered with rubber. Accessories like drainage pump, external hygrometer and wall brackets put the finishing touch to the Munters MK dehumidifiers.

The dehumidification as such takes place in the cooling coil (evaporator) of the dehumidifier following the principle of a water trap. An axial fan pulls ambient air through a coil cooling the air below dew point. Water condensates and is collected in a water tank or a drainage hose. The cooled and dehumidified air is pulled further through a heating coil (condenser) and regains its heat. The additional heat of the compressor results in a slight increase of temperature. By recirculating the air the dehumidification happens fast, effective and careful.

PRODUCT INFORMATION

MK30D

Features

- Robust construction
- Digital multifunctional display
- High mobility
- High dehumidification capacity
- Built-in RH/T sensor for hygrometer function
- Environmentally friendly refrigerant R134A
- Automatic defrost cycle using hotgas bypass
- Maintenance and service friendly design



Model MK30D

Technical Specification

MK

Drying capacity:	
Moisture removal; 30°C, 80% (kg/24h)	30,0
Moisture removal; 20°C, 60% (kg/24h)	13,0
Moisture removal; 10°C, 70% (kg/24h)	6,0
Operational ranges:	
Relative humidity (%)	40-100
Temperature (°C)	3-33
Rated voltage (V/Hz)	230/50
Rated current (A)	2,7
Rated power (W)	590
Energy consumption 30°C, 80% (kWh/kg)	0,47
Air delivery (m ³ /h)	250
Refrigerant type	R134a
Refrigerant mass (g)	410
Water tank capacity (l)	7
Dimensions (incl. handle):	
Width (mm)	414
Depth (mm)	506
Height (mm)	736
Weight (kg)	32
Noise level max (dB, A)	56
Protection class (IP)	X4
Cable Length (m)	3,5

Schematic picture

- A: Ambient air
- B: Evaporator
- C: Condenser
- D: Water tank
- E: Dehumidified air

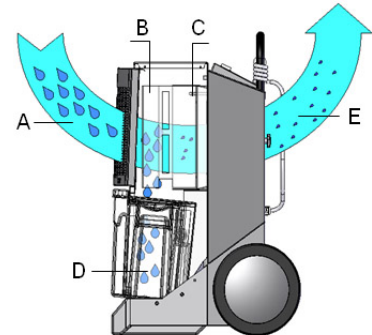

Performance

- Mobile
- Flexible
- Robust
- Automatic defrost (hotgas bypass)
- Digital multifunctional display
- Hour meter
- External signal for Operation and Alarm
- Socket for external hygrostat
- Water tank
- 3.5 m cable length

Options

- Drainage pump installed in water tank
- External Hygrostat
- Wall brackets

AUSTRALIA
Tel +61 2 8843 1588
CHINA
Tel +86 10 804 18000
INDIA
Tel +91 20 668 18 900
NETHERLANDS
Tel +31 172 43 32 31
SWEDEN
Tel +46 8-626 6300
UNITED KINGDOM
Tel +44 1480 432 243

AUSTRIA
Tel +43 1 6164298-0
DENMARK
Tel +45 4495 3355
ITALY
Tel +39 0183 521377
POLAND
Tel +48 58 305 35 17
SWITZERLAND
Tel +41 52 3438886
UNITED STATES
Tel +1 978 241 1100

BELGIUM
Tel +32 2 240 68 68
FINLAND
Tel +358 20 776 8230
JAPAN
Tel +81 3 5970 0021
SINGAPORE
Tel +65 6744 6828
THAILAND
Tel +66 2 642 2670-3
VIETNAM
Tel +84 8 825 6838

BRAZIL
Tel +55 41 3317 5050
FRANCE
Tel +33 1 3411 5757
KOREA
Tel +82 2 761 8701
SOUTH AFRICA
Tel +27 11 997 2000
TURKEY
Tel +90 262 751 3750

CANADA
Tel +1 905 8585894
GERMANY
Tel +49 40-879690-0
MEXICO
Tel +1 52 722 270-4029
SPAIN
Tel +34 91 640 09 02
UNIT. ARAB EMIRATES
Tel +971 4 8809295

www.munters.com

