

# MX<sup>2</sup> 95 Dehumidifier



## Product description

The MX<sup>2</sup> 95 combines traditional Munters strengths like efficiency and robustness with modern state of the art technology like modulating RH control and communication.

Low energy consumption and reliability are important in today's processes. Our modern control system together with high efficient fans which meet the EU Ecodesign directive, supported with frequency converters give you numerous options to optimise your energy consumption. The Energy Recovery Purge (ERP) or Energy Efficiency Purge (EEP) is available as a standard option in order to save energy.

The MX<sup>2</sup> 95 is equipped with a number of alarm functions to ensure total control of the dehumidification process. Frame casing and outer panels are made of corrosion resistant AluZink and coated in RAL 7035.

The MX<sup>2</sup> 95 dehumidifier covers a wide range of needs by providing a variety of standard functions. The numerous options will allow pre- and post-treatment by simply adding mechanical and electrical components.

The MX<sup>2</sup> 95 can be supplied with 3 different reactivation alternatives - electrical, steam and gas. A service indicator activates when a preventative service is due, this is a standard feature. To make installation easier the process fan inlet has been designed to allow for different outlet positions.

The electrical equipment conforms to EN 60204 (IEC204). The MX<sup>2</sup> series of dehumidifiers conform to both harmonised European standards and technical specifications for CE marking.

## Munters Rotor Technology

Munters desiccant rotors are highly effective moisture-absorbing substances. An option for the MX<sup>2</sup> series rotor technology is the ERP or EEP solution reducing the energy consumption.

## PRODUCT INFORMATION

# MX<sup>2</sup> 95

## Features

- Efficient dehumidification between -20°C and 40°C
- Modulating humidity control including wet air temp sensor
- Communication and external control options
- Filter and rotor stop alarm as standard
- Energy saving options
- Service and running indicator alarm as external indicators

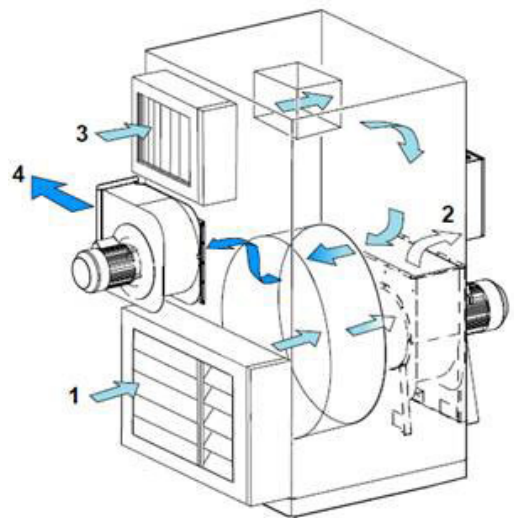

1. Process air
2. Dry air
3. Reactivation air
4. Wet air

# Model MX<sup>2</sup> 95

Diagram measurements are for reference only.

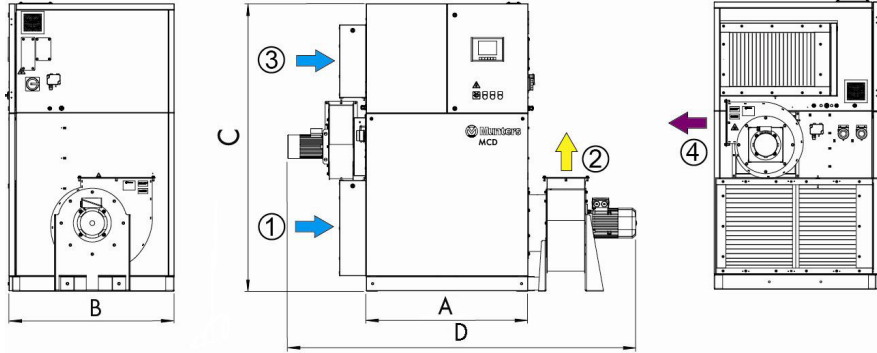

Height (C)	Dry air	Wet air	Weight	Width (A/D)	Depth (B)
2214mm	273x500mm	185x400mm	673kg	1068/2416mm	1307mm

## Technical Specification

### Process Air

Rated airflow (m <sup>3</sup> /h)	9500
Available static pressure (Pa)	300
Fan power (kW)	7.5

### Reactivation air

Rated airflow (m <sup>3</sup> /h)	1800
Fan Power (kW)	1.5
Static Pressure at rated airflow (m <sup>3</sup> /h)	300

### Total power, voltage and current (amps/phase)

Total power (kW) Electrical	69.5
Total power (kW) Steam/Gas	9.5
380V 3-50 Hz (A) Electrical	110
380V 3-50 Hz (A) Steam/Gas	19
400V 3-50 Hz (A) Electrical	105
400V 3-50 Hz (A) Steam/Gas	18
415V 3-50 Hz (A) Electrical	101
415V 3-50 Hz (A) Steam/Gas	17
440V 3-60 Hz (A) Electrical	95
440V 3-60 Hz (A) Steam/Gas	16
Max steam working pressure (bar) (g)	7
Gas consumption (m <sup>3</sup> /h)	5.91
Natural gas pressure (mbar)	18-49
Max sulphur content (ppm) HPS Rotor	30
Steam consumption 3 bar (g/s)	28.1
Steam consumption 5 bar (g/s)	28.8
Total power with ERP,Electrical (kW)	69.5
Steam consumption with ERP 3 bar (g)	28.1
Gas consumption with ERP (m <sup>3</sup> /h)	5.91
Moisture removal 20°C, 60% (kg/24hr)	1150
Steam consumption with ERP 5 Bar (g)	28.8

### Miscellaneous Data

Operating temperature (°C)	-20-+40
Sound power level to room Lw(A) dB, all inlets and outlets ducted	90
IEC protective class (unit)	33
IEC protective class (electrical panel)	54
Filter class	G4
Motor winding insulation	F

## Dehumidification Capacity

Approximate capacity in kg/h at different inlet process air relative humidity % RH

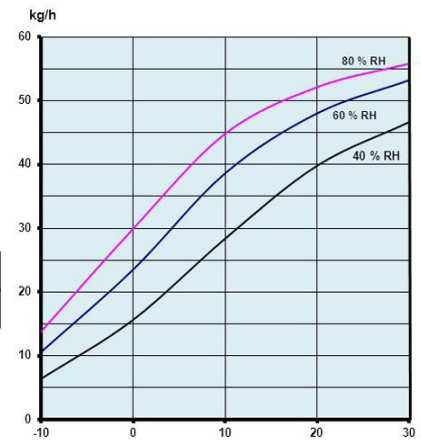

## Options

- Bypass
- Communication via Modbus, BACnet or Lon
- Dewpoint sensor
- Energy Efficiency Purge (EEP)
- Energy Recovery Purge (ERP)
- External controls
- Filters M5, G4 or G4/F7 combination
- Heaters-gas,electric or steam
- Pre-react heaters - heat water or steam
- Insulated process air inlet
- Mirror handed
- Stainless steel casing
- Touch screen display

**AUSTRALIA**  
Tel +61 2 8843 1588  
**CHINA**  
Tel +86 10 804 18000  
**INDIA**  
Tel +91 20 668 18 900  
**NETHERLANDS**  
Tel +31 172 43 32 31  
**SWEDEN**  
Tel +46 8-626 6300  
**UNITED KINGDOM**  
Tel +44 1480 432 243

**AUSTRIA**  
Tel +43 1 6164298-0  
**DENMARK**  
Tel +45 4495 3355  
**ITALY**  
Tel +39 0183 521377  
**POLAND**  
Tel +48 58 305 35 17  
**SWITZERLAND**  
Tel +41 52 3438886  
**UNITED STATES**  
Tel +1 978 241 1100

**BELGIUM**  
Tel +32 2 240 68 68  
**FINLAND**  
Tel +358 20 776 8230  
**JAPAN**  
Tel +81 3 5970 0021  
**SINGAPORE**  
Tel +65 6744 6828  
**THAILAND**  
Tel +66 2 642 2670-3  
**VIETNAM**  
Tel +84 8 825 6838

**BRAZIL**  
Tel +55 41 3317 5050  
**FRANCE**  
Tel +33 1 3411 5757  
**KOREA**  
Tel +82 2 761 8701  
**SOUTH AFRICA**  
Tel +27 11 997 2000  
**TURKEY**  
Tel +90 262 751 3750

**CANADA**  
Tel +1 905 8585894  
**GERMANY**  
Tel +49 40-879690-0  
**MEXICO**  
Tel +1 52 722 270-4029  
**SPAIN**  
Tel +34 91 640 09 02  
**UNIT. ARAB EMIRATES**  
Tel +971 4 8809295

www.munters.com

